

**PROPORTIONNEUR DE MOUSSE**

FOAM PROPORTIONER

Mod. **SE-Z-2** **SE-Z-4**  
**SE-Z-8**



**CARACTÉRISTIQUES PRINCIPALES**

- Boitier en polyacetate (POM)
- Filtre en Acier Inoxidable
- Tube en aluminium
- Vernis: enamel polyurethane (RAL 3000)

**OPTION:**

- Types de connexion: BCN-45, BCN-70, STORZ, BSS, NH, brides DIN ou ANSI.

---

**CONSTRUCTION FEATURES**

- Casing in Polyacetate (POM)
- Strainers in stainless steel.
- Pipe in Aluminium
- Finish: polyurethane enamel (RAL 3000)

**OPTIONAL**

- Connection types: BCN-45, BCN-70, STORZ, BSS, NH or DIN - ANSI flanges.

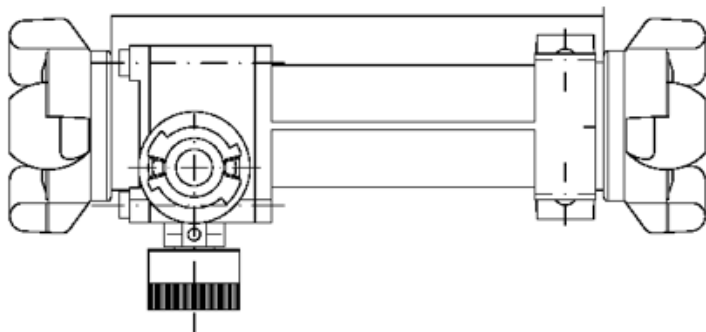
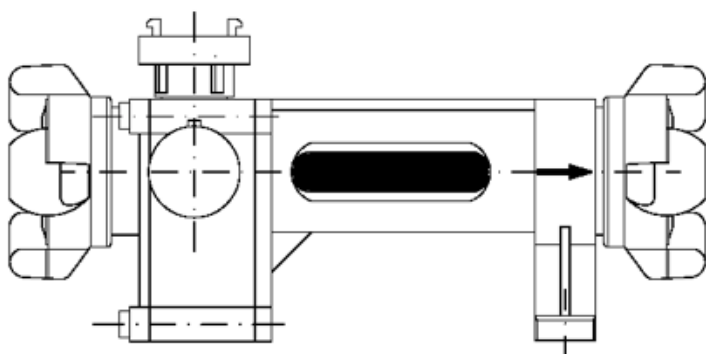

MODELO MODEL	CAUDAL FLOW RATE L/min. 5 bar	PORCENTAJE MIXING RATIO %	CONEXIONES CONNECTIONS inch - mm	PÉRDIDA DE CARGA PRESSURE LOSS %	DIMENSIONES DIMENSIONS			PESO WEIGHT kg
					L (mm)	W (mm)	H (mm)	
SE-Z-2	200	0 - 6	2" BSP - 50/60	38	356	135	152	2.150
SE-Z-4	400	0 - 6	2" BSP - 50/60	38	362	135	152	2.300
SE-Z-8	800	0 - 6	2" BSP - 50/60	38	362	135	152	2.300