

■ DATA SHEET PROPORTIONER FD2500 FOR STATIONARY EXTINGUISHING SYSTEMS.

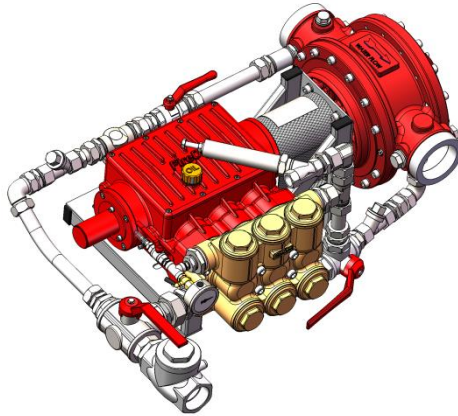

■ 1. TECHNICAL DATA.

Proportioning rate	0.5%	1%	3%	6%	3% + 3%
Approvals	-	FM 3039305 ¹		-	-
	-	VdS G4060028 ¹		-	-
	DNV-GL TAF00000GK ²				
Flow directions of water motor	Horizontal: "left → right" or "right → left" Vertical: "top → bottom" or "bottom → top"				
Min. water flow rate ³	250 l/min	250 l/min	250 l/min	350 l/min	350 l/min
Min. water flow rate ³ with flow reduction	90 l/min	90 l/min	90 l/min	120 l/min	120 l/min
Max. water flow rate	2500 l/min				
Operating temperature	5 °C – 50 °C				
Max. operating pressure	16 bar				
Weight ⁴					
Freshwater version	54 kg	65 kg	82 kg	130 kg	115 kg
Seawater version	97 kg	120 kg	125 kg	173 kg	157 kg
ATEX classification (optional) ⁵	Ex CE II 2G IIC c T4 / II 2D IIIC c T<130°C				

1) Applies to pump generation I.

2) Applies to pump generation I and II.

3) Proportioning starts even at a lower water flow rate. The nominal proportioning rate is achieved when reaching the specified figure.

4) Weight indication is based upon a proportioner with a service crank. Further accessories installed at the proportioner will increase the specified weight. Weight indications do not consider extinguishing water or foam agent.

5) The proportioner does not have a service crank if it is an ATEX version. Divergent materials are possible.



ISO 9001:2015
Certificate No.: 12 100 16020/01 TMS
ISO 14001:2015
Certificate No.: 12 104 16020/01 TMS



www.firedos.com

2. PRESSURE LOSS.

The actual pressure loss may slightly vary, depending on the operating conditions.

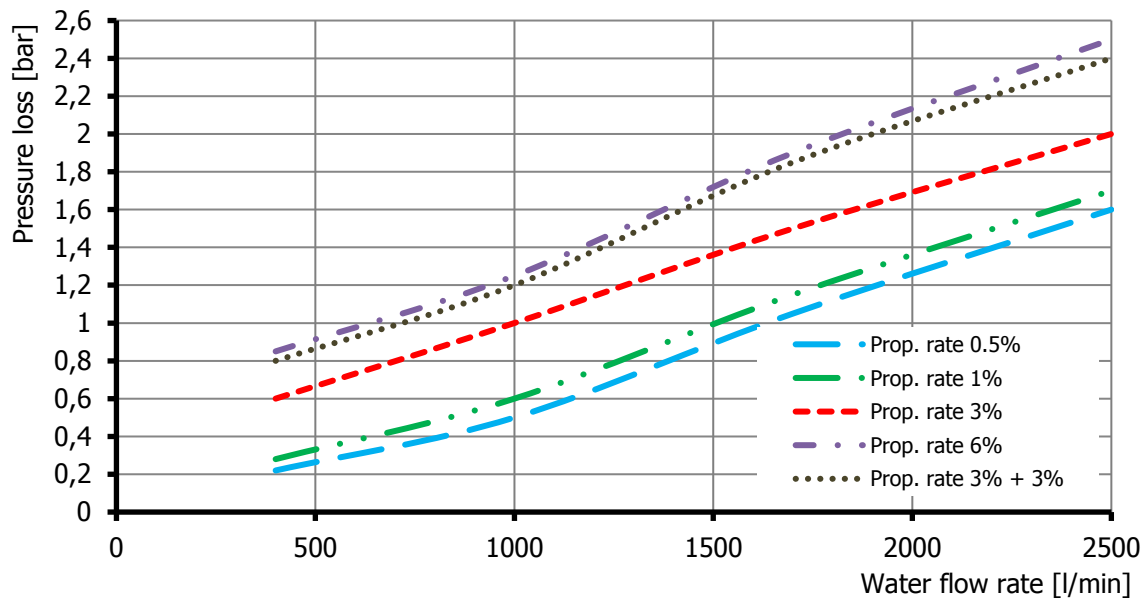

3. MATERIALS.

	Freshwater version	Seawater version
Water motor	Aluminium casting G- $AlSi_7Mg$ HC-coated, $AlMgSi_1$ anodised, stainless steel V2A, POM, PVDF, NBR, FPM	Bronze casting $CuSn_{10}$, stainless steel V4A, Aluminium-Bronze, POM, PVDF, NBR, FPM
Prop. pump	Stainless steel V4A, POM, FPM, ceramics, aluminium bronze	Stainless steel V4A, POM, FPM, ceramics, aluminium bronze
Pipework	Stainless steel V2A and V4A, PTFE, FPM, nickel-plated brass, aluminium bronze	Stainless steel V4A, PTFE, FPM, aluminium bronze

4. FLOW DIAGRAM WITH RETURN LINE CONNECTION.

Proportioning rate 0.5% / 1% / 3% or 6%

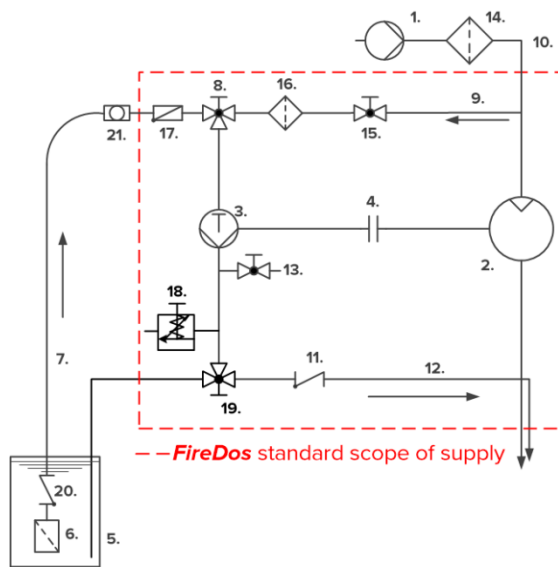

Proportioning rate 3% + 3%

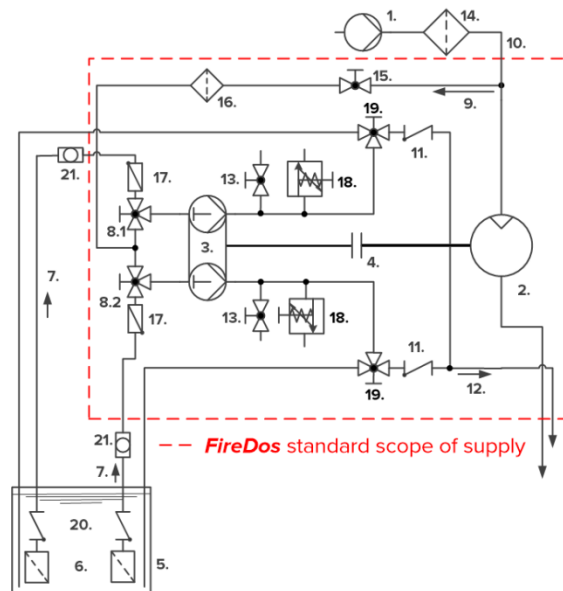

1. Extinguishing water supply
2. Water motor
3. Proportioning pump
4. Coupling
5. Foam agent supply
6. Foot filter
7. Suction line
8. 3-way ball valve "Flushing/Priming"
- 8.1 "Flushing/Priming" pump head I
- 8.2 "Flushing/Priming" pump head II
9. Flushing line
10. Extinguishing water line

11. Check valve in the proportioning line
12. Pressure/proportioning line
13. Air bleed valve
14. Filter in the extinguishing water line
15. Gate valve in the flushing line
16. Filter in the flushing line
17. Non-return flap in the suction line
18. Pressure-relief valve
19. 3-way ball valve "Admixing/Returning"
20. Foot valve*
21. Ventilation/Filling of the suction line*

*) Necessary only with a non-constant course of the suction line

5. EXAMPLE FIGURE / DIMENSIONS.

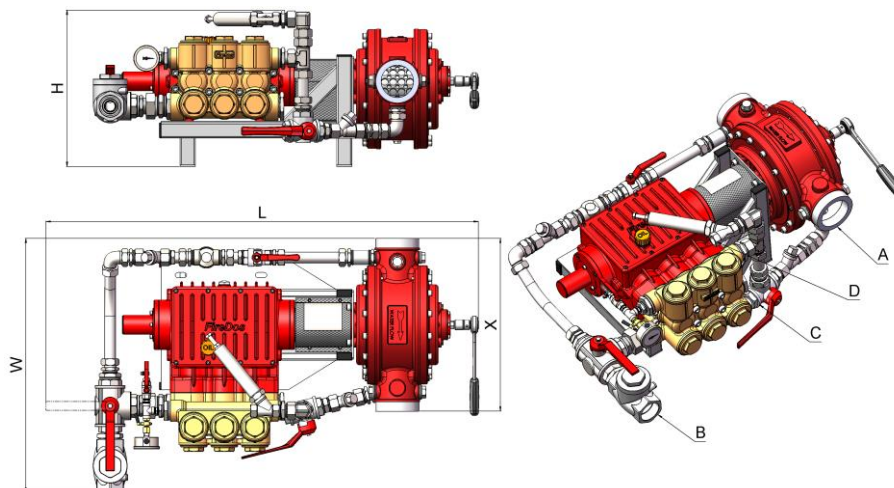

Proportioning rate	0.5%	1%	3%	6%	3% + 3%
Connection water motor A	Optionally: Thread 4" male thread BSP, 3" female thread BSP (standard) Flange acc. to DIN 2566, DN100 PN16 Flange acc. to ANSI B16.5, 4"-150 lbs/in ² Flange acc. to JIS B2220 20K-100				
Connection suction line B ⁶					
Pump generation I	1 ¼" FT BSP	1 ¼" FT BSP	1 ¼" FT BSP	-	-
Pump generation II	-	1 ¼" FT BSP	2" FT BSP	2 ½" FT BSP	2x 2" FT BSP
Connection return line C	1" FT BSP	1" FT BSP	1" FT BSP	1" FT BSP	2x 1" FT BSP
Connection pressure-relief valve D	¾" FT BSP	¾" FT BSP	¾" FT BSP	¾" FT BSP	2x ¾" FT BSP
Length L ⁷	962 mm	959 mm	1210 mm	1305 mm	1196 mm
Height H ⁷	373 mm	373 mm	373 mm	408 mm	608 mm
Width W ⁷	500 mm	552 mm	525 mm	558 mm	747 mm
Installation length in the pipework X	Thread 452 mm Threaded flange acc. DIN 470 mm Threaded flange acc. JIS 474 mm Threaded flange acc. ANSI 478 mm				

All figures are approximate only and depend on the particular version/equipment options.

6) We will be pleased to advise you on which pump generation to use for your purpose.

7) Further accessories to the proportioner may require more installation space.

Please allow sufficient accessibility of the proportioner for maintenance work.

6. MANUFACTURER.

FireDos GmbH, Auf der Kaulbahn 6, 61200 Wölfersheim, Germany

Phone +49 (0) 6036 9796-0, Email: info@firedos.de

We reserve the right to make modifications at any time.