

LANZA ESPUMA DE MEDIA EXPANSIÓN
MEDIUM EXPANSION FOAM BRANCHPIPE

Mod. **SE-SME 18**
SE-SME 24



CARACTERÍSTICAS CONSTRUCTIVAS

- Cuerpo y material lanza de acero inox AISI 304
- Cuerpo y material collector: ASTM A 105/106 gr.B

OPCIONAL

- Cuerpo y material lanza AISI 316
- Cuerpo y material collector AISI 304 o AISI 316

PRESTACIONES

- El caudal puede ser calculado como: $Q=K* \sqrt{P}$
- Relación de expansión: 1:40
Dependiendo del espumógeno
- Presión de trabajo (recomendada): de 2,5 a 6 bar

CONSTRUCTION FEATURES

- Body and nozzle branch pipe material: stainless steel AISI 304.
- Inlet collector material: ASTM A 105/106 gr.B

OPTIONAL

- Body in stainless steel material AISI 316
- Flanges in stainless steel material AISI 304 or AISI 316

PERFORMANCE

- Flow rate can be calculated as: $Q=K* \sqrt{P}$
- Expansion ratio: 1:40
The foam production understands with fresh air
- Working pressure (advised): de 2,5 a 6 bar

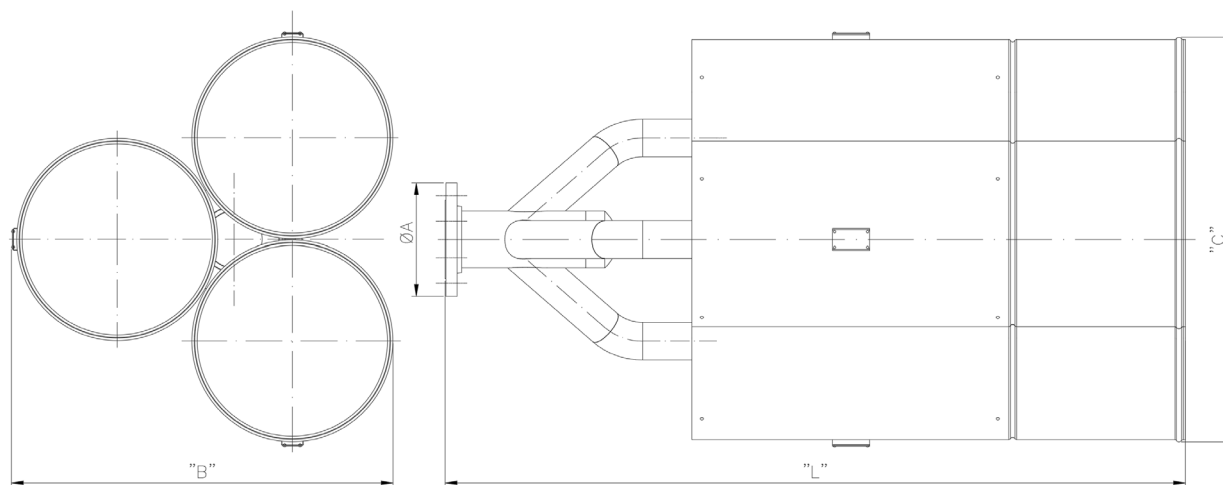

MODELO MODEL	FACTOR K K FACTOR	CAUDAL FLOW RATE l/min.@5bar	ALCANCE THROW m@5 bar	"ØA" DIN PN-16 / ANSI- 150-RF	"B" mm.	"C" mm.	"L" mm.	PESO WEIGHT Kg
SE-SME-18	805	1800	9	4"	775	820	1500	61,5
SE-SME-24	1073,3	2400	10	5"	775	820	1500	64