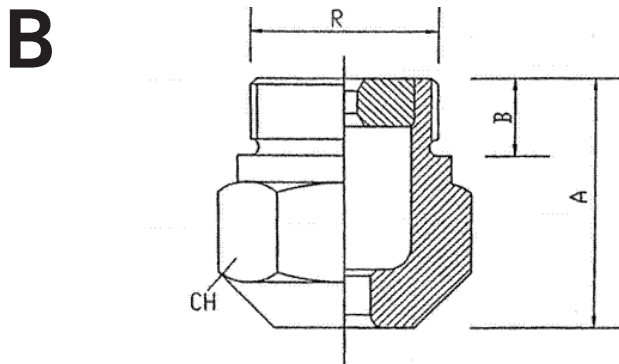
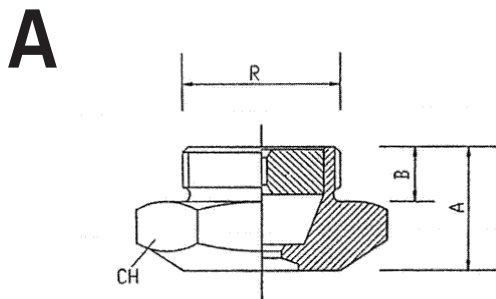

BUSES DE PULVÉRISATION PLEIN
 SPRAY NOZZLES FULL

 Mod. **SE-FC**

CARACTÉRISTIQUES DE CONSTRUCTION

- Angle de dispersion 45° - 60° - 90°
- Matériau en laiton
- Filetage 1/2" BSP (GAZ)

SUR DEMANDE

- Autres matériaux
- Autres coefficients K
- Filetage 3/4"
- Fil NPT

CONSTRUCTION FEATURES

- Dispersion angle 45° - 60° - 90°
- Material: brass
- Thread 1/2" BSP (GAS)

BY REQUEST

- Other materials
- Other K coefficients
- Thread in 3/4"
- NPT thread

CARACTÉRISTIQUES DE CONSTRUCTION

- Angle de dispersion 120°
- Matériau en laiton
- Filetage 1/2" BSP (GAZ)

SUR DEMANDE

- Autres matériaux
- Autres coefficients K
- Filetage 3/4"
- Fil NPT

CONSTRUCTIVE FEATURES

- Dispersion angle 120°
- Material: brass
- Thread 1/2" BSP (GAS)

BY REQUEST

- Other materials
- Other K coefficients
- Thread in 3/4"
- NPT thread

R	CAUDAL EN LPM A LA PRESIÓN BAR FLOW IN LPM AT PRESSURE BAR						DIMENSIONES DIMENSIONS			TIPO	R	CAUDAL EN LPM A LA PRESIÓN BAR FLOW IN LPM AT PRESSURE BAR						DIMENSIONES DIMENSIONS		
	1	2	3	5	7	10	A	B	CH			1	2	3	5	7	10	A	B	CH
2 1/2"	280	400	490	630	750	900	52	30	90	FC 1025	2 1/2"	280	400	490	630	750	900	124	30	90
2"	180	250	310	400	474	566	44	25	75	FC 820	2"	180	250	310	400	474	566	85	25	75
1 1/2"	142	200	240	316	370	448	35	20	55	FC 618	1 1/2"	142	200	240	316	370	448	77	20	55
1 1/2"	112	160	194	250	296	354	35	20	55	FC 616	1 1/2"	112	160	194	250	296	354	77	20	55
1 1/4"	70	100	123	160	190	230	30	20	50	FC 512, 5	1 1/4"	70	100	123	160	190	230	62	20	50
1"	45	63	78	100	120	140	28	18	36	FC 410,5	1"	45	63	78	100	120	140	50	18	36
1"	35	50	61	80	95	113	28	18	36	FC 49	1"	35	50	61	80	95	113	50	18	36
3/4"	28	40	49	63	75	90	28	17	30	FC 38	3/4"	28	40	49	63	75	90	38	17	30
3/4"	22,5	31,5	39	50	59	70	28	17	30	FC 36,9	3/4"	22,5	31,5	39	50	59	70	38	17	30
3/4"	18	25	31	40	47	57	28	17	30	FC 36,3	3/4"	18	25	31	40	47	57	38	17	30
3/4"	14	20	25	32	37	45	27	15	22	FC 26,3	3/4"	14	20	25	32	37	45	27	15	22
3/4"	11,5	16	20	25	30	35	27	15	22	FC 25,3	3/4"	11,5	16	20	25	30	35	27	15	22
1/2"	9	12,5	15,5	20	24	28	27	15	22	FC 24,4	1/2"	9	12,5	15,5	20	24	28	27	15	22