

# USD DOUBLE TANK VERTICAL AVEC EMULSEUR A L'INTERIEUR DE LA VESSIE

VERTICAL PRESSURE PROPORTIONING SYSTEM WITH FOAM CONCENTRATE INSIDE OF THE BLADDER (TWIN TANKS)

Mod. **SE-MXC-I-2X**

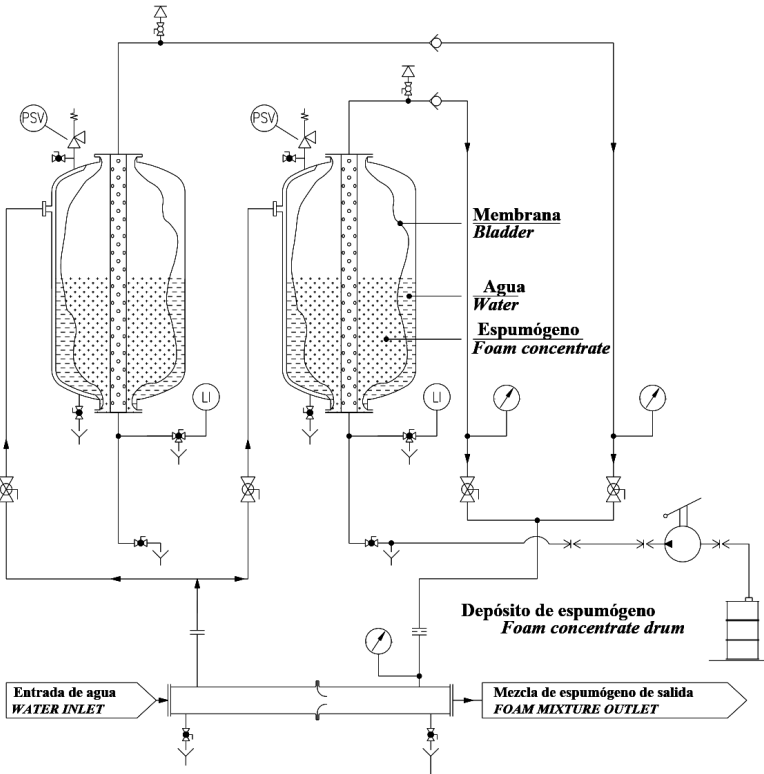

- Línea de agua y espumógeno  
Water and concentrate lines
- Válvula de esfera  
Ball valve
- Válvula de esfera de tres vías  
Three way ball valve
- Diafragma de espumógeno calibrado  
Calibrated foam diaphragm
- Diafragma de agua calibrado  
Calibrated water diaphragm
- Válvula de antirretorno  
Check valve
- PSV — Válvula de seguridad  
Safety valve
- Válvula de venteo  
Vent valve
- Manómetro  
Pressure gauge
- Rácord  
Quick connection
- Mezclador  
Mixer
- Depósito de espumógeno  
Foam tank
- Indicador del nivel de espuma  
Foam level indicator
- Bomba manual carga de espumógeno (NO INCLUIDA)  
Manual foam concentrate filling pump (NOT INCLUDED)

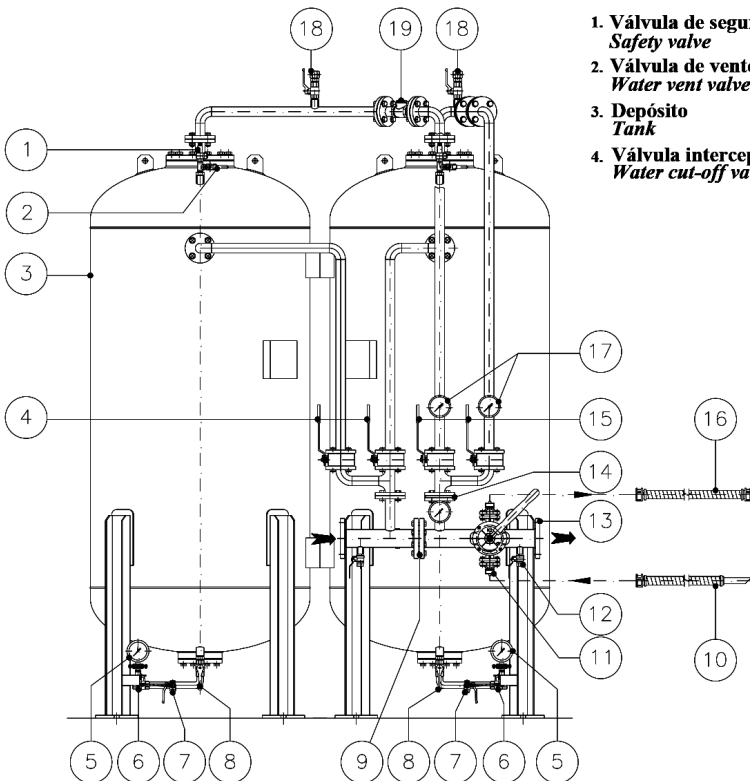

1. Válvula de seguridad  
Safety valve
2. Válvula de venteo de agua  
Water vent valve
3. Depósito  
Tank
4. Válvula intercepción agua  
Water cut-off valve
5. Indicador de nivel de espumógeno  
Concentrate level indicator
6. Válvula carga/drenaje espumógeno  
Concentrate filling/drain valve
7. Válvula de drenaje indicadora del nivel de espumógeno  
Concentrate level indicator drain valve
8. Válvula de drenaje de agua  
Water drain valve
9. Diafragma calibrado  
Water calibrated diaphragm
10. Tubo flexible  
Flexible hose
11. Bomba de carga (NO INCLUIDA)  
Fill pump (NOT INCLUDED)
12. Válvula de drenaje del mezclador  
Mixer drain valves
13. mezclador  
Mixer
14. Diafragma calibrado de espumógeno  
Foam calibrated diaphragm
15. Válvula de intercepción de espumógeno  
Concentrate cut-off valve
16. Tubo flexible  
Flexible hose
17. Manómetro depósito  
Tank pressure gauge
18. Válvula de venteo/sobrellenado espumógeno  
Concentrate vent valve/overflow valve
19. Válvula antirretorno  
Check valve

**USD DOUBLE TANK VERTICAL AVEC EMULSEUR A L'INTERIEUR DE LA VESSIE**

VERTICAL PRESSURE PROPORTIONING SYSTEM WITH FOAM CONCENTRATE INSIDE OF THE BLADDER (TWIN TANKS)

Mod. **SE-MXC-I-2X**

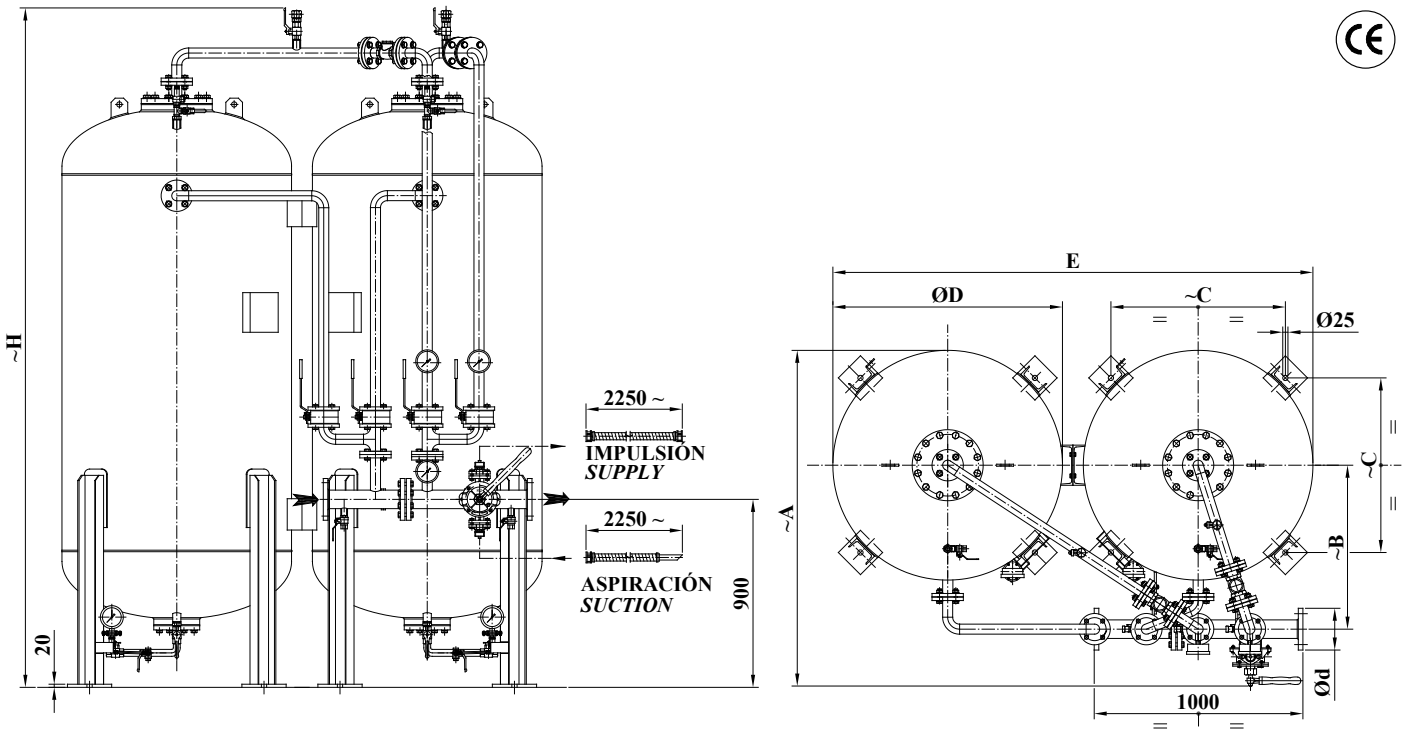

**NOTE:** Les caracteristiques de construction et autres informations sont montrés dans les pages précédentes

**NOTE:** Construction features and more information are shown in the previous page.

CAPACIDAD CAPACITY L	MEZCLADOR 3" MIXER 3"			MEZCLADOR 4" MIXER 4"			MEZCLADOR 6" MIXER 6"			MEZCLADOR 8" MIXER 8"			PESO WEIGHT kg*				
	"Ød"	"A" mm.	"B" mm.	"Ød"	"A" mm.	"B" mm.	"Ød"	"A" mm.	"B" mm.	"Ød"	"A" mm.	"B" mm.		"C" mm.	"ØD" mm.	"E" mm.	"H" mm.
1000	3"	1510	735	4"	1535	745	6"	1590	775	8"	1635	795	765	1000	2100	2470	1133
1500	3"	1510	735	4"	1535	745	6"	1590	775	8"	1635	795	765	1000	2100	3120	1430
2000	3"	1610	785	4"	1635	795	6"	1690	825	8"	1735	845	835	1100	2300	3255	1652
2500	3"	1710	835	4"	1735	845	6"	1790	875	8"	1835	895	920	1200	2500	3383	2079
3000	3"	1810	885	4"	1835	895	6"	1890	925	8"	1935	945	995	1300	2700	3557	2325
3500	3"	1910	935	4"	1935	945	6"	1990	975	8"	2035	995	1065	1400	2900	3630	3014
4000	3"	1960	960	4"	1985	970	6"	2040	1000	8"	2090	1025	1100	1450	3000	3756	3205
4500	3"	2010	985	4"	2035	995	6"	2090	1025	8"	2140	1050	1135	1500	3100	3785	3332
5000	3"	2110	1035	4"	2135	1045	6"	2190	1075	8"	2245	1105	1210	1600	3300	3740	3487
5500	3"	2110	1035	4"	2135	1045	6"	2190	1075	8"	2245	1105	1210	1600	3300	3990	3715
6000	3"	2260	1110	4"	2285	1120	6"	2340	1150	8"	2395	1180	1315	1750	3600	3840	4600
6500	3"	2310	1135	4"	2335	1145	6"	2395	1180	8"	2445	1205	1350	1800	3700	3865	4694
7000	3"	2510	1235	4"	2535	1245	6"	2595	1280	8"	2645	1305	1500	2000	4100	3570	4980
7500	3"	2510	1235	4"	2535	1245	6"	2595	1280	8"	2645	1305	1500	2000	4100	3720	5183
8000	3"	2510	1235	4"	2535	1245	6"	2595	1280	8"	2645	1305	1500	2000	4100	3920	5458
8500	3"	2510	1235	4"	2535	1245	6"	2595	1280	8"	2645	1305	1500	2000	4100	4070	5665
9000	3"	2510	1235	4"	2535	1245	6"	2595	1280	8"	2645	1305	1500	2000	4100	4220	5869
10000	3"	2510	1235	4"	2535	1245	6"	2595	1280	8"	2645	1305	1500	2000	4100	4570	6358
11000	3"	2510	1235	4"	2535	1245	6"	2595	1280	8"	2645	1305	1500	2000	4100	4870	6784
12000	3"	2510	1235	4"	2535	1245	6"	2595	1280	8"	2645	1305	1500	2000	4100	5220	7268

\* Le tableau montre le poids approximatif de système de mélange sans le proportionneur; le poids du proportionneur doit être ajouté pour obtenir le poids total.

\* The table shows the approximate weight of proportioning system without mixer; The mixer weight must be added to obtain the total weight. The proportioning system are considered standard.