

DEVERSEUR MOUSSE

FOAM POURER

Mod. **SE-VF**

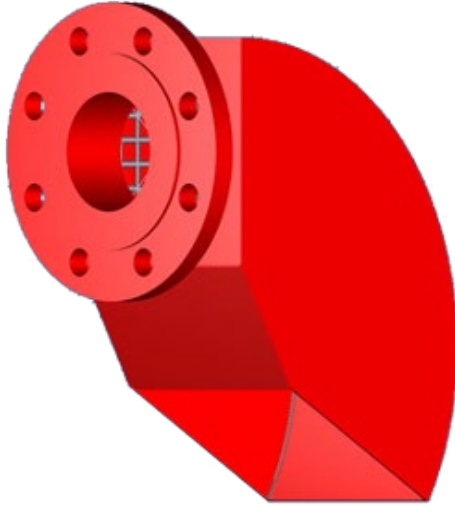

CARACTÉRISTIQUES DE CONSTRUCTION:

- Corps en acier au carbone
- Bride en acier au carbone
- Finition: émail polyuréthane (RAL 3000)

OPTION

- Corps en acier inoxydable (AISI 304 / AISI 316)
- Grille de protection: AISI 316
- Galvanisation à chaud

NOTE: Spécifier la version (DIN ou ANSI) à la commande

CONSTRUCTION FEATURES

- Body material: carbon steel
- Flanges material: carbon steel
- Finish: polyurethane enamel (RAL 3000)

OPTIONAL

- Body material: stainless steel (AISI 304 / AISI 316)
- Strainer material: stainless steel AISI 316
- Hot dip galvanized

NOTES

- Specify version (DIN/ANSI) on the order

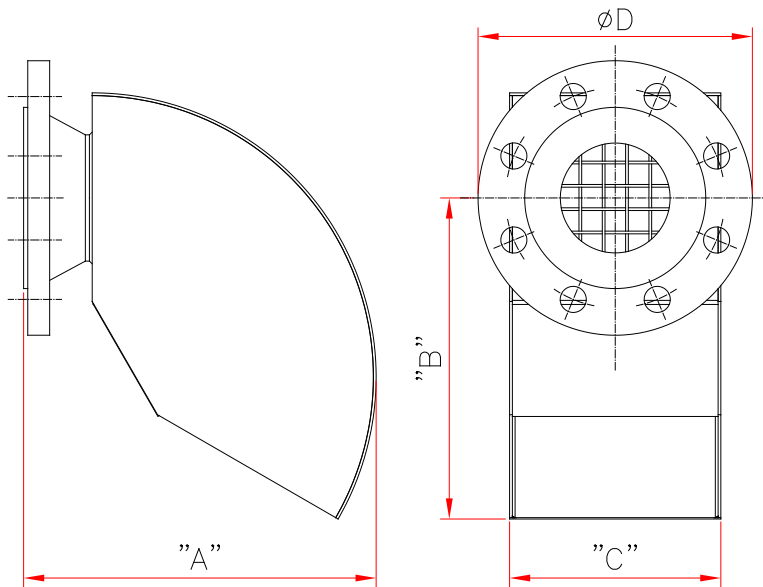

MODELO MODEL	"A" DNI (ANSI) mm.	"B" mm.	"C" mm.	"ØD" mm.	PESO WEIGHT Kg
SE-VF-3	257 (277)	234	154	3"	7,2 (7,5)
SE-VF-4	259 (283)	234	154	4"	8 (10,5)
SE-VF-6	312 (346)	284	204	6"	12,4 (15,8)
SE-VF-8	369 (409)	334	254	8"	17,8 (24,5)
SE-VF-10	427 (458)	384	306	10"	27,4 (37,2)
SE-VF-12	485 (521)	434	356	12"	36,6 (54,7)